

CAD FILE:

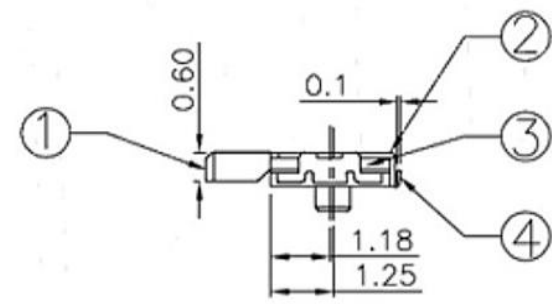

包装规格: 载带包装

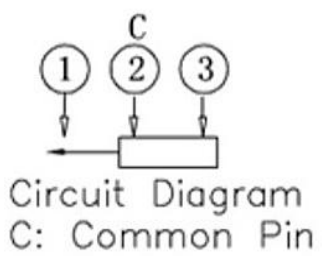
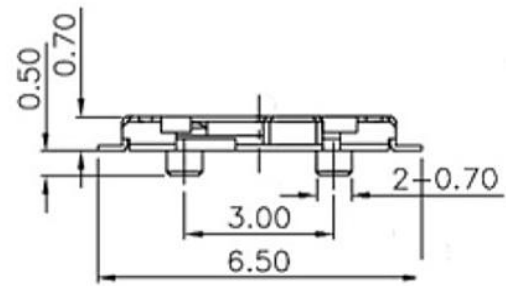
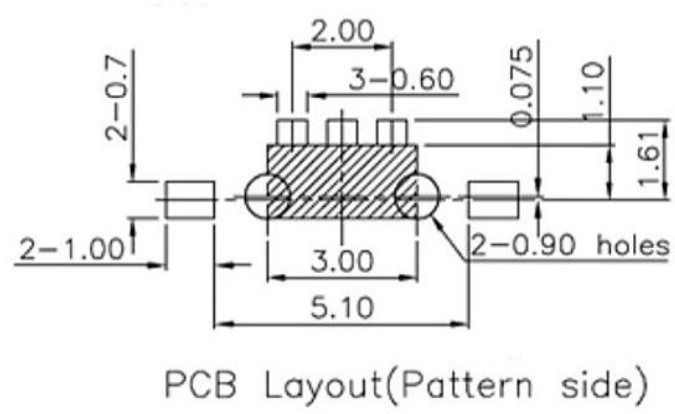
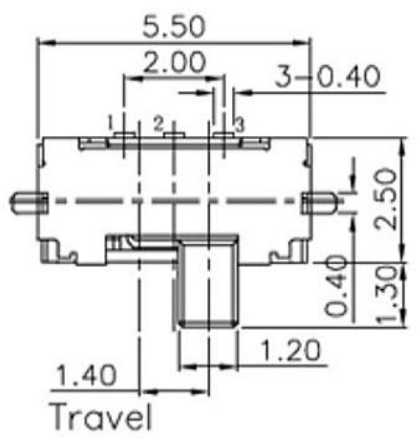
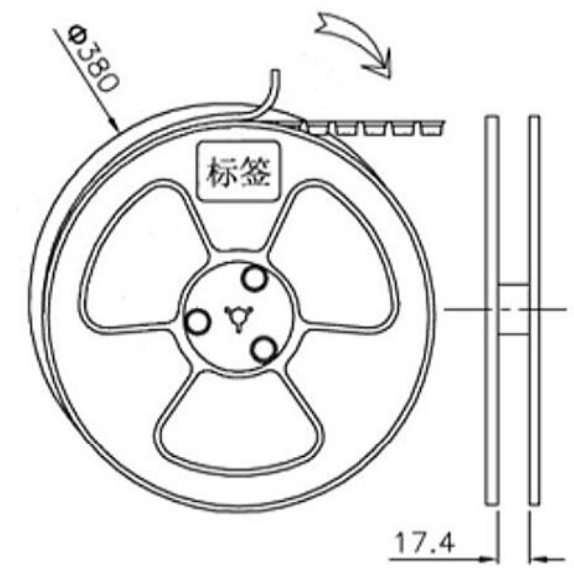

数量 (PCS):  
1盘: 5000

注: "\*"表示关键尺寸(6个)

NO.	PARTS	MATERIALS	Q'TY	FINISH	TOLERANCE UNLESS SPECIFIED	DATE	REV	DESCRIPTIONS OF REVISION	APPD.	
8										
7	STEEL BALL	STEEL	1	NATURAL						
6	SPRING	STEEL WIRE	1	NATURAL						
5	CONTACT CLIP	PBS STRIP	2	Ag PLATED						
4	TERMINAL	BRASS STRIP	8	Ag PLATED						
3	BASE	PHENOLIC RESIN	1	NATURAL						
2	FRAME	STEEL STRIP	1	Ni PLATED						
1	KNOB	POM	1	BLACK						
					TITLE : SLIDE SWITCH		UNIT : mm		DRWG NO.:	
					MODEL:		SCALE: 3:1		DWN. 2012-10-26	
					<b>东莞市高迪电子有限公司</b> DONGGUAN GAODI ELECTRONICS CO., LTD.		ISSUE		2012-10-26	
							DATE		初版	
							APPD.		2012-10-26	